

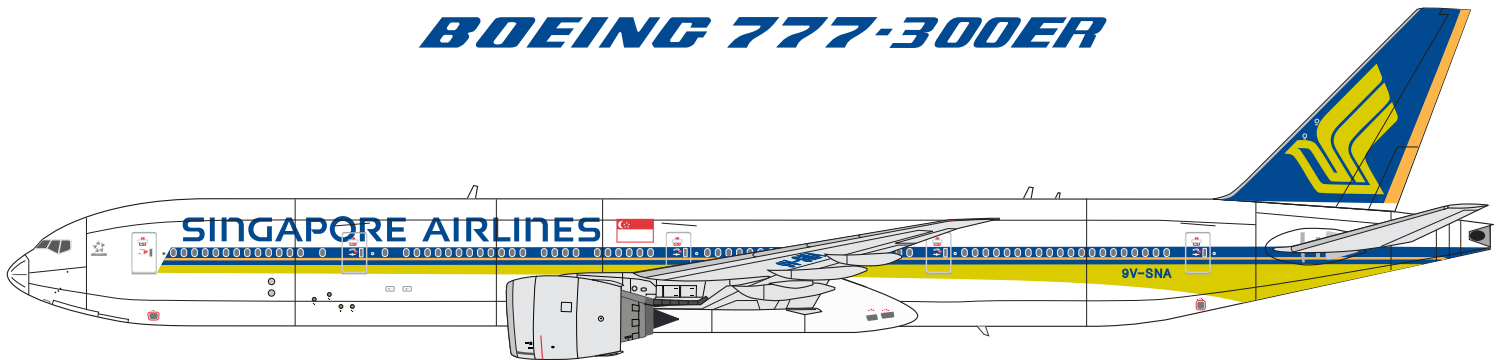

For the 1/144 Scale
Revell or Zvezda
Boeing 777-300ER Kit

SINGAPORE AIRLINES

BOEING 777-300ER



Singapore Airlines has one of the most beautiful and elegant schemes ever carried on the Boeing 777-300ER. With 27 in service, at time of writing, they can be seen all around the world flying some of the carrier's longest and most prestigious routes, with the first one entering service on December 5, 2006 on the Singapore - Paris route.

Paint the fuselage overall gloss white with the wings in the standard Boeing colors of Boeing Grey with a bare-metal leading edge. The horizontal stabilizers are overall grey with bare-metal leading edges. Apply fuselage and tail decals as showing in the drawings. Apply wing escape route and black ice-detection strip as shown in the drawings. The large registration number goes on the bottom of the left wing. Registration sequences for the -300ERs start with 9V-SNA and 9V-SWA.

Note:

- The first deliveries had large Singapore logos on the engine cowlings but were eventually removed and none of them currently have any logos on the engines.
- The bare-metal rubbing plate is a little bigger on the #3 door.
- Window patterns vary slightly. Check photos of the actual aircraft you are building to verify the window pattern.
- Apply the white door pieces after the grey door outlines have completely dried.
- Some extra pieces of some parts are provided incase you damage any.
- Refer to the drawings and image below as well as photos on the internet to build an accurate model of the exact aircraft you are building.
- On the engine cowlings, be sure to apply the same parts on the same side of both engines. For example, the left side of engine #1 will have the same stenciling as the left side of engine #2 and vice versa.
- We have not been able to find a single Singapore 777-300ER with corroguard either on the top or bottom of the wings

Small Detail Parts:

- The parts in section CD are for the Cargo Doors.
- The parts in section E are for the Engines.
- The parts in section F are for the fuselage.
- Parts labeled WL are the wing-root lights.

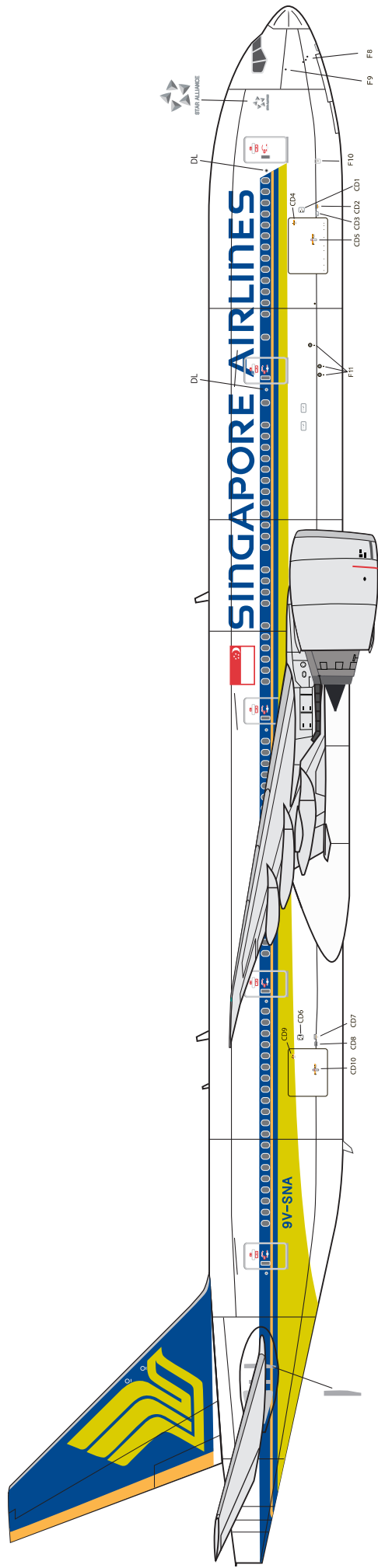
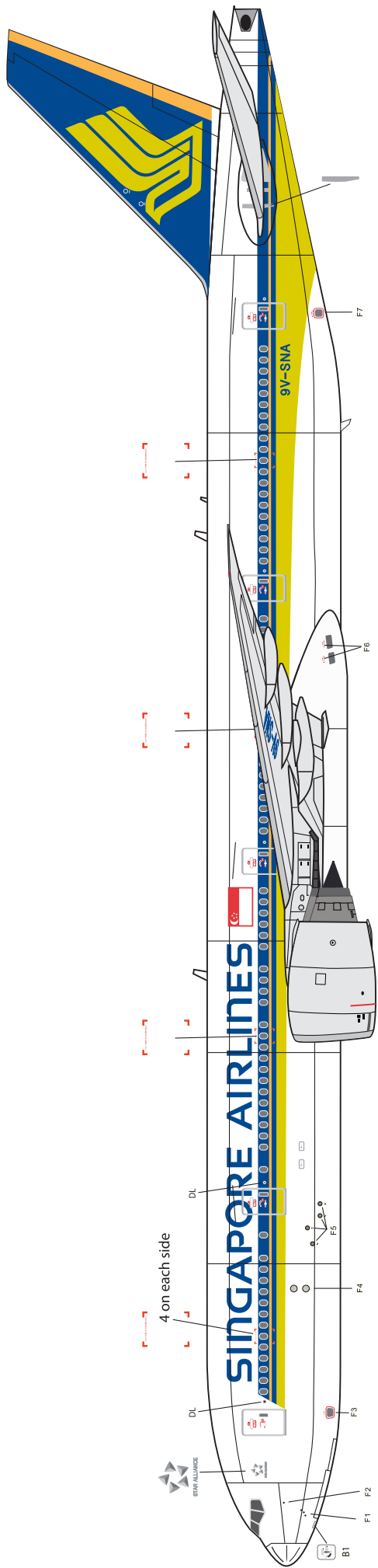

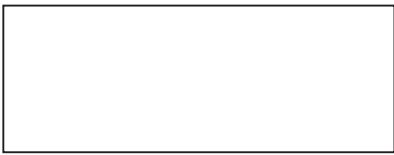
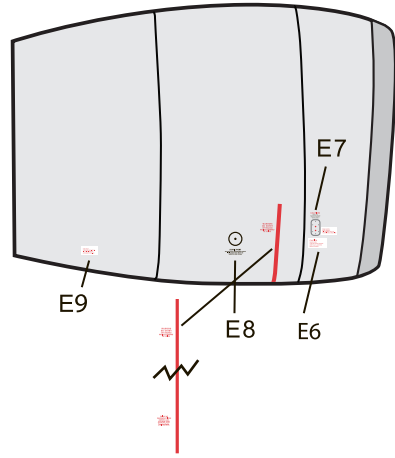
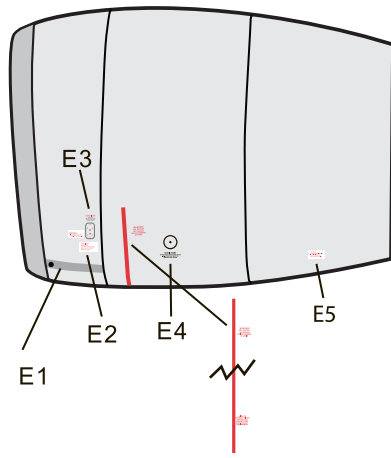
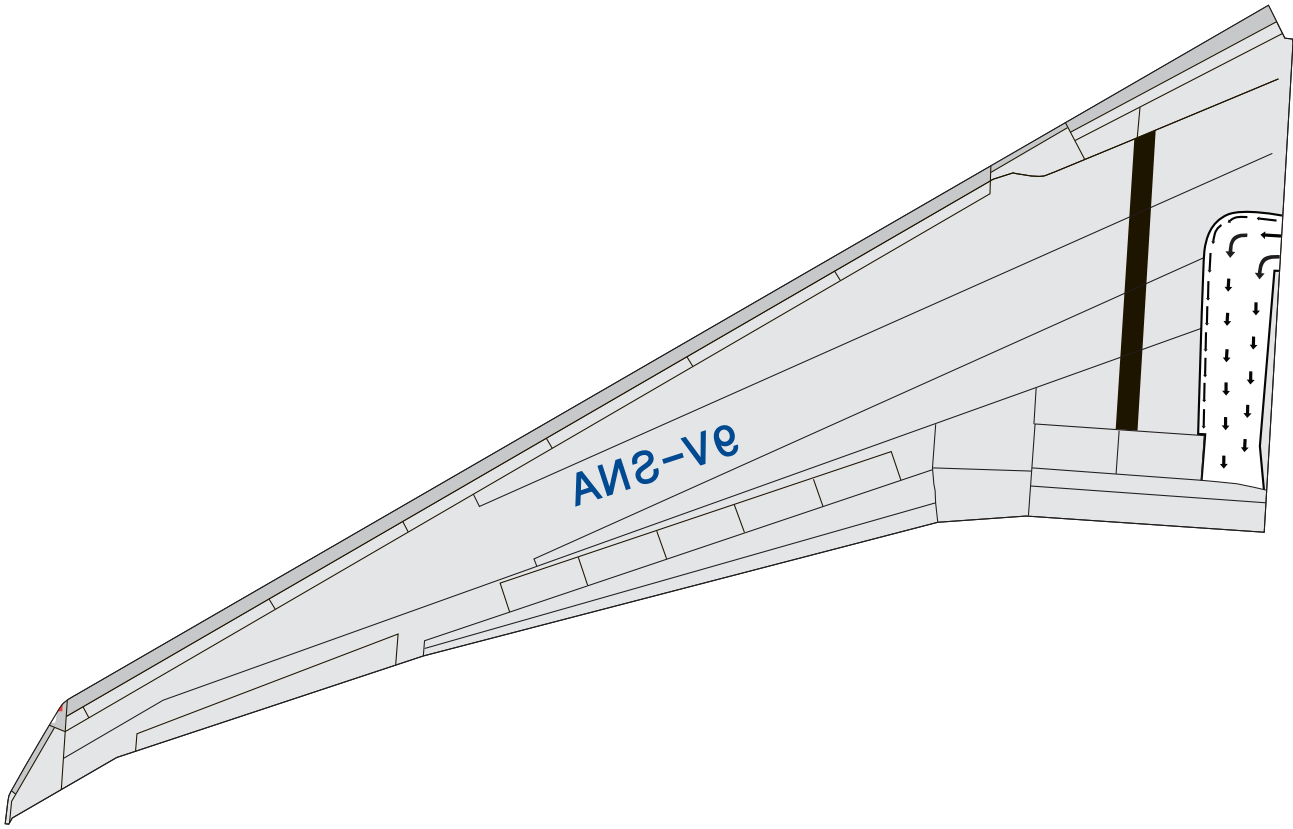

Gloss White



Boeing Gray



Bare Metal